

SERIES E-200-C SIGNAL-MARKING GENERATOR

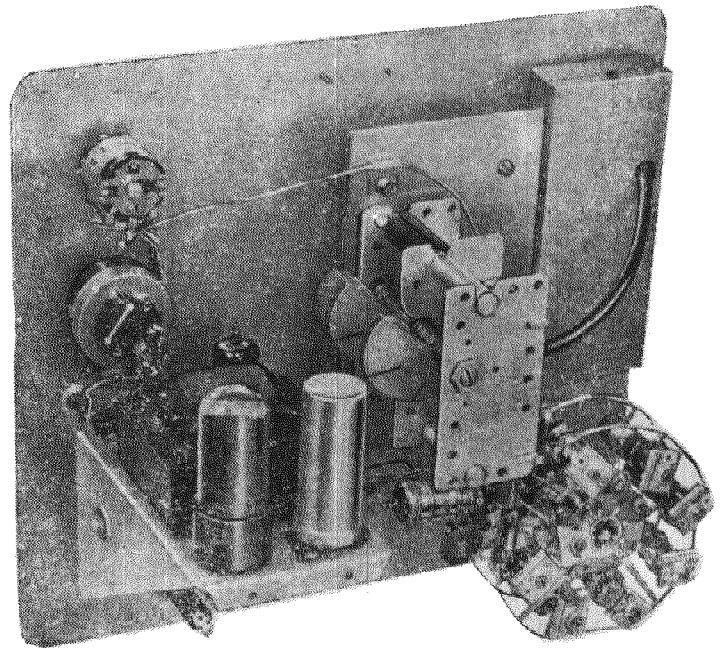

INTERIOR VIEW SHOWING RF TURRET CONSTRUCTION

PRECISION

Apparatus

OPERATING INSTRUCTIONS SIGNAL GENERATOR

Series E-200-C

PRECISION APPARATUS Division of Dynascan Corporation
1801 W. Belle Plaine
Chicago, Illinois 60613

THE SERIES E-200-C SIGNAL-MARKING GENERATOR

The series E-200-C Signal-Marking Generator is a thoroughly modern A.C. operated instrument. It is a highly accurate, reliable and stable source of variable frequency standards for all general radio frequency alignment, adjustment and test problems, including F.M. and T.V. applications.

Included are direct facilities for audio frequency tests with a separate 400 cycle, sine-wave audio oscillator.

The usual Dynascan high standards of materials and workmanship have not been spared and as will be noted from the following important features, our engineers have embodied every technically advanced circuit and operational feature providing for the utmost in accuracy, utility and ease of manipulation.

May we call to your attention that on the pages immediately preceding will be found both pictorial illustrations and a schematic diagram of this highly unusual Signal-Marking Generator. Reference to same while reading the following would be of valuable assistance in more fully understanding the operational features described.

1. The A.V.C. Substitution System.

Supplying its own A.V.C. voltage from a directly calibrated network, (V-15—see schematic), the Series E-200-C eliminates the necessity for critical Signal Generator and receiver control settings to keep alignment procedure below the A.V.C. threshold. This voltage is independently adjusted to coincide with the actual A.V.C. voltage developed by the receiver under normal average conditions of reception and accordingly assures accurate and efficient alignment of all tuned circuits, as described in detail on page 7 and following.

2. Eight Bands.

Provide a continuous coverage from 88 kilocycles through 440 megacycles; 88 KC through 110 MC on fundamentals.

Band A: (88-230 KC)	Band F: (15-29 MC)
Band B: (220-600 KC)	Band G: (29-55 MC)
Band C: (550-1700 KC)	Band H: (55-110 MC)
Band D: (1.60-5.0 MC)	Band H ₂ : (110-220 MC)
Band E: (5-15.5 MC)	Band H ₄ : (220-440 MC)

Special oscillator design produces strong harmonics whereby the very high frequency ranges (110-220 MC) and 220-440 MC) are generated with the same high order of stability and accuracy as the original band. The (110-220 MC) band is calibrated directly on the dial as band H. The (220-440 MC) range is read on band H.

Bands "F", "G" and "H" are electrically band spread enabling precise settings to fractions of a megacycle, especially useful for video I.F. marking in television receivers.

Eight bands, are used to provide unusually wide band-spread of true electrical nature, allowing easy direct reading of the dial, in frequency, to 440 MC. An eight position, positive acting band selector switch provides for simple selection of any desired range.

3. Accuracy - Constancy of Calibration.

A 6AU6 (see schematic) in the "Unit-Oscillator" construction provides shortest possible leads between oscillator and associated circuits. All components including coils, trimmers, condensers, socket, tube, resistors, etc., are actually mounted right onto the band switch, as illustrated in the picture on the front cover.

High quality, ceramic spaced band switch, silver plated switch contacts, ceramic suspended trimmers, plus silver mica $\pm 1\%$ padder condenser and SLF tuning condenser in addition to the rugged "Unit-Oscillator" construction, insures $+1\%$ Accuracy on All Bands under widely varying conditions. This permits use of Series E-200-C for complete F.M. receiver alignment as well as for TV marker and other TV applications. See page (18).

4. The Circuit - Frequency Stability.

As will be noted from inspection of the circuit diagram, the Series E-200-C uses a miniature 6AU6 in a highly stable electron-coupled oscillator circuit, modulated in the output buffer-amplifier section by a separate 400 cycle, sine-wave audio oscillator. A dual tube, type 6U8, which consists of a triode and pentode in one envelope is used as a combined audio oscillator, amplifier, and cathode follower output tube. By accomplishing modulation in the amplifier section, rather than the more usual method of modulating the oscillator directly, minimum frequency instability is assured even at high modulation levels. This thereby permits the Series E-200-C to provide completely variable modulation control from zero to 100%. In such manner, the comparative signal audibility, as against the usual 30% modulated oscillator, is increased by over 300% (this is especially advantageous when adjusting receivers badly out of alignment), without the need of raising the R.F. signal voltage to over-load proportions.

Utilizing a non-interfering dual R.F. output attenuation system (V-10, V-11 and associated components) the oscillator frequency is unaffected by output loads or R.F. control settings. The use of a COAXIAL OUTPUT CABLE provides appropriate connections for test requirements. A type 5Y3 full-wave rectifier forms the foundation of a heavy duty, hum-free D.C. voltage supply. A four point selector switch provides, AT WILL, automatic selection of 4 types of test signal voltages.

1. Unmodulated R.F., commonly referred to as C.W.
2. 400 cycle internally modulated R.F.
3. Externally modulated R.F.
4. 400 cycle sine-wave audio output.

5. Large Full Vision 6½" Dial and Vernier Scale with Twin Engraved Plastic Hairline Indicator.

An engine turned, non-tarnishing, permanent, anodized finished, 14 gauge aluminum dial with deeply etched scales and numerals provides almost seven feet of direct easy reading scale length. A smooth operating, and more costly ball-bearing planetary drive system eliminates string and belt-drive difficulties, insuring stability in dial settings.

The etched vernier segment and circumferential 0-107 hand calibrating scale provides direct reading to one part in 1000 for critical laboratory usage (see page 19). The transparent hair-line indicator affords direct frequency readings, free from parallax.

6. 400 Cycle Sine-Wave Oscillator – Independently Controlled.

A 6U8 audio frequency oscillator and cathode follower output provides the modulation tone, as well as being available for external test applications. The unusually high audio voltage output of almost 80 volts peak (fully controllable from zero to maximum), allows for the DIRECT testing of audio power-output and other circuits, absolutely independent of all other stages. This is of primary importance in "SERVICING BY SIGNAL SUBSTITUTION" as well as in routine amplifier troubleshooting.

Examination of the Series E-200-C schematic diagram will show that the audio oscillator circuit is fully isolated from external circuits and voltages by reason of the cathode follower output stage.

7. Dual R.F. Attenuator – Low Leakage.

Thorough shielding; electrostatically shielded power transformer; R.F.-filtered power line connections; shielded coaxial cable connectors; coaxial output cable; in addition to a triple shielded DUAL R.F. ATTENUATION NETWORK, calibrated for stage by stage R.F. gain comparisons.

8. Variable Modulation Control, Direct Reading.

Another new and advantageous feature of Series E-200-C, specifically designed for "S-S-S", is the calibrated Modulation Control which provides, At Will 0-100% modulation of the R.F. signal. This feature originated in previous models, more than triples signal utility and audibility as against Signal Generators applying only fixed 30% modulation. This high level of modulation, free from annoying frequency instability, is possible only through the application of the audio signal to the R.F. Amplifier. This feature is in direct accord with transmitter practice.

9. No "Dead Spots."

The design of the "UNIT-OSCILLATOR" (front cover), is such that ALL inductances, not in use, are COMPLETELY shorted out of the circuit, thereby eliminating signal absorption due to free-floating coils, which would produce unusable portions in a Signal Generator's frequency range.

10. Audio and R.F. Signals Independent of Each Other.

This is an original PRECISION "S-S-S" feature, whereby the Series E-200-C serves as BOTH an audio and R.F. Signal Generator, at the same time, with non-interfering operation; allowing for simultaneous test on tuners and audio amplifiers by two separate operators. The R.F. signal may be used unmodulated while the audio signal is being utilized at another point. This same independence of R.F. and audio controls provides complete flexibility of the type of R.F. signal voltage employed. In other words, the modulation percentage

(and type of modulation) can be freely varied WITHOUT HAVING TO TOUCH EITHER ONE OF THE R.F. ATTENUATORS.

11. Amplified External Modulation Input.

The four position "Audio Signal" selector switch provides for modulation of the R.F. signal from external sources, when the switch is set to the "EXT. MOD." position. In this position the audio oscillator tube operates as a high gain amplifier thus enabling the E-200-C to be adequately modulated by low level external signal sources such as crystal type phonograph pick-ups.

12. Frequency Modulation – Television.

The alignment of F.M. receivers is readily and easily accomplished directly with the Series E-200-C. An actual F.M. signal is NOT mandatory. See page (13).

However, when desired, a frequency modulated signal for oscillographic methods of alignment is readily obtained through the use of Series E 310-C or equal Sweep Signal Generator. By connecting the coaxial output cable of the Series E-200-C to the marker input terminals of the Sweep Signal Generator, E-200-C thereby becomes a variable frequency marker signal generator.

The fundamental requirements of a service-laboratory type Signal-Marking Generator is to provide, unfailingly, a source of RELIABLE and ACCURATE frequency standards for the adjustment and alignment of R.F. circuits. Fulfilling this requirement, Series E-200-C readily provides up-to-the-minute application as an A.M. generator for trap adjustments in T.V. receivers as well as for peaking alignment of stagger-tuned T.V. -I.F. stages. In addition, Series E-200-C is a very convenient source of variable marker signals when aligning T.V. sets with a sweep signal generator. It furthermore permits rapid, accurate, overall band width checkup via the moving marker method. See page (18). Incidentally a frequency modulated signal generator is best employed only when a high sensitivity laboratory type cathode-ray oscillograph is also on hand, such as SERIES ES-550B.

13. Fused Line Circuit.

A special front panel fuse post provides full protection against the accidental use of improper voltage sources and further protects the instrument against prolonged high voltage surges.

14. Tubes.

This instrument employs one each of the following:
6AU6 – Electron coupled R.F. oscillator-amplifier.
6U8 – Audio oscillator-modulator, audio amplifier, cathode follower output.
5Y3 – Full wave rectifier.

The foregoing, in conjunction with the schematic should give the reader a well-rounded idea of the exceptionally well planned background and design of the Series E-200-C service-laboratory Signal-Marking Generator.

GENERAL OPERATING INSTRUCTIONS

TAKE NOTE THAT THIS INSTRUMENT HAS BEEN DESIGNED FOR A.C. OPERATION ONLY, FROM ANY 110-120 VOLTS, 50-60 CYCLE SOURCE, UNLESS SPECIFICALLY FURNISHED FOR OTHER VOLTAGE AND/OR FREQUENCY.

Before using the Signal Generator, it is advisable to allow the instrument to "warm up" for a period of at least 10 minutes. In this manner, all vital components are given a chance to come to normal operating temperature, insuring the utmost accuracy and stability of the output frequency. A rotary type A.C. LINE SWITCH is on the "A.V.C. CONTROL" located at the center right-hand side of the instrument panel. A 30 degree rotation turns power "ON" and leaves the "A.V.C. CONTROL" ready for use, in zero volts position.

Immediately set "RF CONTROL-1", "RF CONTROL-2", and the "MODULATION CONTROL" to their respective zero positions.

After the pre-heat period has elapsed, the instrument is ready for operation. Procedure at the receiver end should be in accord with manufacturers' alignment instructions found in service manuals and service notes. Generalized alignment procedures will be found further on in this instruction book and serves only as a GUIDE in the event of absence of exact adjustment notations. Use of A.V.C. Substitution is optional with the operator and when not employed, the setting of the "A.V.C. CONTROL" in no way affects the operation of the instrument or the alignment procedure. The proper use of A.V.C. Substitution is described under the generalized receiver adjustment instructions.

Determine whether a Dummy Antenna is required for the operations about to be performed. In general, it is good practice to use a Dummy Antenna whenever the Signal Generator Output Cable is to be connected directly across an inductance such as the primary winding of the antenna coil. In such case the Universal I.R.E. all-wave dummy antenna is recommended and can be assembled in very little time as will be noted upon examination of the sketch below. Necessary components can be purchased from the usual well-stocked distributors of radio parts.

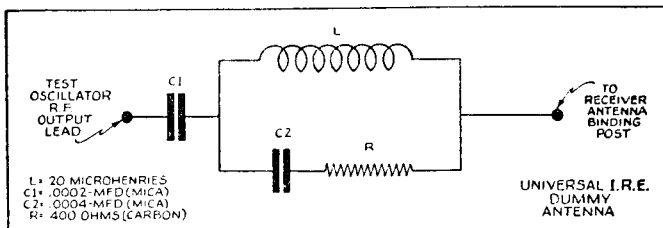

The Coaxial Output Cable, which screws on to the Coaxial Cable Connectors at the left hand side of the instrument panel, terminates in two colored leads with alligator

clips. The identification of these leads is as follows:

BLACK — Ground

RED — Output direct from live center terminal of coaxial cable output connectors.

A Dummy Antenna, when required, is connected in series with the RED lead and may consist of an inductance, capacitance, resistance, or combination, as may be called for.

IF CONNECTIONS ARE TO BE MADE ACROSS A CIRCUIT WHICH IS AT A POTENTIAL DIFFERENCE FROM GROUND, a blocking condenser must be inserted in series with the RED lead to prevent a D.C. short due to the continuity of the R.F. Attenuation network. A capacity of .002 mfd., rated at 400 working volts, will usually be sufficient for all purposes. Smaller values of capacity may be used according to the demands of circuit loading conditions.

After determining whether a Dummy Antenna is called for or not, make proper output lead connections, ALWAYS MAKING GROUND CONNECTIONS FIRST. Both Signal Generator and receiver under alignment should preferably be at the SAME ground potential. The most practical means of doing this is to ground the Signal Generator to the receiver chassis and then connect the receiver chassis itself to a good ground. The cold water pipe is generally sufficient.

CAUTION: In the case of "AC-DC" receivers, wherein one side of the line may be tied directly to the receiver chassis, it is necessary to use a blocking condenser in series with the lead between receiver and ground, or else a short circuit will occur in one position of the receiver line cord plug. This condenser should be approximately .1 mfd. 400 W.V.

Next rotate the "BAND SELECTOR", located at the lower left hand corner of the panel, to the frequency range desired and rotate the "TUNING KNOB", until the red hair-line pointer is at the required frequency on the band selected. For special reference purposes, there will be found on page (18) of this book an outline on how to use *the numerical reference scale and vernier*.

After having made the proper "Band Switch" and "Dial" settings for the frequency desired, set the "AUDIO SIGNAL" switch (located at the lower right hand corner of the panel) to either the "Unmodulated R.F." or "Modulated R.F." position, depending upon whether the visual resonance aid or output meter you are employing is in some portion of the R.F. or I.F. circuits or the audio output stage, respectively. The generalized alignment procedure given further on in this book details placement of visual resonance aids.

Now adjust the "MODULATION CONTROL" to 30% or 40% Modulation position. See page (20) of this book. 30% Modulation is usually sufficient for NORMAL alignment procedure, but if the receiver proves to be greatly out of line, higher modulation percentages may be chosen as necessary, for better audibility.

NOTE: Inasmuch as we are now going through the usual method of receiver alignment, the operator must bear in mind to always employ the SMALLEST R.F. signal intensity NECESSARY for the alignment procedure. The reason for this is that in this manner, the automatic volume control system, if any, will not function, and we thereby avoid the undesirable leveling action of automatic volume control.

For those not fully familiar with this action of A.V.C. circuits, it should be understood that the purpose of automatic volume control is to maintain constant R.F. signal input to the detector over a wide range of signal intensity applied to the receiver antenna terminals. In brief, the greater the input signal strength to the antenna post, the greater the A.V.C. voltage developed, which, applied to the control grids of the R.F. and I.F. amplifier stages, reduces their gain proportionately. In the other direction, a reduction in antenna signal carries with it the development of smaller A.V.C. potentials, and accordingly, the stages controlled by the A.V.C. network operate under conditions of reduced bias or increased gain.

Hence, unless the test signal is kept below the point at which A.V.C. takes hold, trimmer adjustments will be automatically followed by changes in A.V.C. voltage, and in this manner, the receiver will attempt to maintain constant output in spite of signal variations due to trimmer adjustments. Of course, there are methods of aligning a receiver with automatic volume control working, but the resonance indicators, in such cases, cannot be just a simple output meter, but must be associated in some way or other with the tuned circuits or A.V.C. controlled stages.

Let us now continue with the alignment procedure from the point where we briefly departed. The R.F. output attenuators are operated as follows.

The system for controlling the magnitude of the R.F. output voltage consists of a coarse adjustment potentiometer, "R.F. CONTROL-1", which feeds the vernier (smooth) output "R.F. CONTROL-2". This latter potentiometer directly controls the R.F. output voltage appearing at either the "LOW" or "HIGH" coaxial cable output connectors. In general, the "LOW" output terminal will suffice unless the receiver is badly misaligned, or the test requires unusually high output; at such time the "HIGH" output terminal is employed. The screw-cap allows shielding of the unused terminal to minimize leakage possibilities from this source.

The setting of "R.F. CONTROL-1" determines the MAXIMUM voltage available with "R.F. CONTROL-2" turned fully on. This latter control is self-calibrating for comparative gain measurements, and allows division of whatever maximum voltage is made available from "R.F. CONTROL-1", into 100 parts proportional to the numerical setting chosen.

For example, with "R.F. CONTROL-2" at No. 7, only 7/10 of the full voltage is being supplied to the output system; at No. 5 only 5/10 and at No. 1 only 1/10, etc.

With the foregoing in mind, set "R.F. CONTROL-1" about mid-way between the zero and No. 1 mark, and then rotate "R.F. CONTROL-2" until an appreciable indication appears on the resonance indicator or output meter. If insufficient or no indication appears, bring "R.F. CONTROL-2" back to its zero position and advance "R.F. CONTROL-1" a bit further (in other words, increasing the maximum available signal). Now again rotate "R.F. CONTROL-2" to the right, watching

the resonance indicator for deflection. If still little or no indication is obtained, return "R.F. CONTROL-2" back to its zero position, further increase setting of "R.F. CONTROL-1", and repeat the previous process until adequate deflection of resonance or output indicator is obtained.

When a discernible output indication is finally obtained, then proceed to make the necessary capacitive or inductive adjustments to the circuit under alignment. As the output indication increases with alignment, reduce the R.F. signal input accordingly, to protect the output meter, and at the same time to prevent overloading of the stages being adjusted. In addition this latter measure will insure operation below the A.V.C. threshold (the point at which the A.V.C. system takes hold). The circuit is at resonance when adjusted to give peak indication on the indicating device employed. We then proceed with alignment of the next stage, in accord with the preceding paragraphs, making new frequency settings when necessary, and circuit adjustments in accordance with the set manufacturers' service notes.

In passing, it may be well to restate, at this time, that it is not always necessary to use a modulated R.F. signal to align a radio receiver. As an example, one may use an unmodulated signal and obtain resonance indications from the A.V.C. circuit by using the receiver's own TUNING EYE, a V.T.V.M. or else a 20,000 ohms per volt sensitivity D.C. voltmeter, across the A.V.C. load resistor. These and other methods are covered in the section dealing specifically with resonance indicators, page (8).

THE AUDIO TEST SIGNAL

This instrument employs a separate audio oscillator-modulator. The two pin jacks located in the "AUDIO SIGNAL" selector box, at the lower right hand corner of the panel, provide the external audio test signal. The high impedance (500,000 ohms) of this circuit is suitable for direct connection to the grid of amplifier stages or to high impedance input circuits of audio amplifiers. Audio test connections should be made in accordance with the pin jack markings. The "HIGH" pin jack is for connection to the amplifier tube grid or the high side of an amplifier's input terminals and of course, the "GND" pin jack to the amplifier's low or ground side.

The peak open-circuit voltage available at these two pin jacks is about 75 to 100 volts at a frequency approximating 400 cycles. The signal intensity is fully controllable from zero to maximum by clockwise rotation of the "MODULATION CONTROL". The Audio Signal is available when the "AUDIO SIGNAL" selector is set to the "400 CYCLE AUDIO" position.

A .01 mfd. 400 W.V. blocking condenser is already included in series with the "HIGH" terminal to prevent D.C. short-circuiting in the event that it is necessary to make con-

nections to the plate side of interstage audio transformers, resistance or impedance coupling networks or to any other circuits wherein the potential is either above or below ground.

Before aligning a radio receiver, it is always good practice to test the audio section first, by applying a stage-by-stage signal. In this manner one may readily locate the cause of non-functioning in a receiver as being due solely to circuit troubles in the audio section.

NOTE: When it is desired to feed the Audio Test Signal into a low impedance circuit, such as a 15, 50, 200, 500, or 600 ohm, etc., input, the audio output jacks should not be connected directly to such loads or else the audio oscillator may be thrown out of oscillation due to the reflected low impedance into the high impedance oscillator grid and plate networks. In such instances, an appropriate impedance matching transformer or resistive pad should be employed to transform the high impedance audio output to the desired low impedance. A pad effect may be roughly approximated by utilizing a 50,000 to 100,000 ohm resistor in SERIES with the test lead from the "HIGH" pin jack and a resistor ACROSS the low impedance amplifier terminals. This latter resistor should approximate the input impedance in order to properly load the amplifier input circuit.

For example, if the input impedance of an amplifier were 500 ohms and an impedance matching transformer was not available to match the audio oscillator output, nor a properly designed pad, merely place a 50,000 to 100,000 ohm resistor in series with the lead from the "HIGH" pin jack to the high side of the amplifier 500 ohm input, and then a 500 ohm resistor directly across the 500 ohm input terminals; with the "GROUND" pin jack, of course, connected to the low or ground side of amplifier input terminals.

When doing this, the maximum voltage actually supplied to the amplifier input terminals is materially reduced, since the two resistors act (in addition to an impedance matching device), as a voltage divider. In this particular case, only about 500/100,000 or 1/200th of the oscillator output, or about .5 volt maximum is available; but this is still more than sufficient to feed the input stage of an amplifier.

Many other applications will be found for using your Signal Generator. As an example, the voltage available through the A.V.C. Substitution System is pure D.C. and is completely variable from zero to approximately 50 volts. The D.C. voltage output is obtained from the polarized "A.V.C. VOLTAGE" tip jacks. This voltage may be employed in place of batteries in tests or experiments as long as the current drain is not above approximately 10 milliamperes.

A few other applications of this A.V.C. Voltage Substitution System are:

1. Ohmmeter circuits
2. "B" Supply for low current drain 45 volt battery operated radios and hearing aids
3. Grid bias for audio as well as R.F. amplifier stages
4. Polarizing voltages for testing leakage in low working voltage electrolytic condensers, etc.

GENERALIZED R.F. ALIGNMENT AND ADJUSTMENT and use of THE A.V.C. SUBSTITUTION METHOD

It is almost impossible to give exact alignment procedures for the many varieties of circuits that will be met with in the course of one's servicing experience. It is advised that AT ALL TIMES direct reference should be made to either service manuals or manufacturers' instructions for specific details. The manufacturer is always best qualified to state the special steps necessary for proper alignment of his particular set.

The information which follows is therefore presented in an all-inclusive nature, being fully aware of the fact that there is no rule so definite, to which there is no exception. However, *the general approach* is in all cases more or less similar.

Before beginning alignment, all tube shields and chassis bottom plate (if any), if possible, should be in position. The line-up screw driver or socket-type trimmer adjusting tool should have little or no metal, to prevent capacity effects upon the tuned circuits. A "tuning wand" is sometimes desirable, but not necessary, to determine the direction of the required alignment correction before touching the inductive or capacitive adjusting screws or nuts.

As with the Signal Generator, it is advisable to allow approximately a 10 minute warm-up period of the receiver, to permit all circuits and components to come to normal operating temperatures. Adjustments may then commence with the Signal Generator set to the same frequency as the R.F. or I.F. stages being aligned.

USUAL ALIGNMENT PRACTICE and A.V.C.

It has been commonly accepted practice to automatically align ALL radio receivers incorporating A.V.C., with the volume control set at maximum and the Signal Generator adjusted to deliver very low signal output. This has been done in an attempt to avoid the broad resonance curve effect introduced whenever the signal was of sufficient intensity to cause action of the A.V.C. system as outlined on page (5). But as can be readily proven and demonstrated, a receiver so aligned has not been properly adjusted for NORMAL conditions of broadcast reception, because the volume control, in regular usage, is NEVER set to maximum position and very definite A.V.C. voltage *is* developed. This can be understood when one realizes that the received signal is of much greater intensity than the small Signal Generator output, necessarily employed to operate BELOW the A.V.C. threshold.

Therefore, when the receiver is aligned under conditions of maximum sensitivity (as it would be when the A.V.C. system is not working), there is a very great difference between the grid bias conditions on the R.F. and I.F. stages than when the receiver is installed in the home or elsewhere for NORMAL conditions of reception.

How does this difference in grid bias affect the tuned R.F. and I.F. stages? The explanation is quite simple.

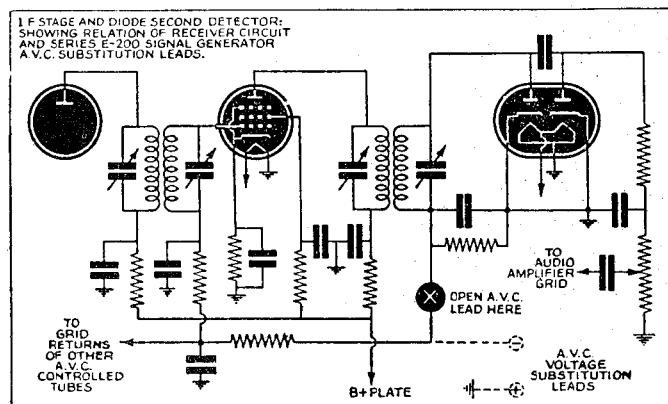

The diagram illustrates a commonly employed I.F. stage and diode second detector, wherein the grid bias is obtained from an A.V.C. network. Concentrate on the input (grid) side of this intermediate frequency amplifier.

The input circuit consists of the grid of the tube and the secondary of the interstage I.F. transformer, the transformer return network and the semi-variable tuning condenser, which resonates the I.F. transformer winding to the intermediate frequency. For the sake of illustration, we shall assume this is approximately 460 Kc, one of the common I.F.'s. In addition to the I.F. trimmer condenser, there are still other capacities effectively bridged across the I.F. transformer secondary, and hence, in parallel with the trimmer condenser. These consist of stray circuit capacities, which are the capacities between wiring as well as to the chassis, plus the very finite capacity which exists between the prongs of the tube and between the socket contacts. To this we add another important factor, and that is the INPUT CAPACITY of the I.F. amplifier tube itself.

Just upon examination of the schematic for the tube, the reader can immediately see that the control grid is physically located between the cathode and screen grid. As we all know, when two or more pieces of metal are brought close to the other, we have, in effect, a capacitor. In this particular case, the capacitor consists of the capacity of grid to cathode and grid to screen plus even the additional capacities of grid to suppressor, and grid to plate.

These latter two capacities are, for a properly designed screen grid tube circuit, comparatively small and almost negligible. However, the capacity of the grid to cathode and screen alone can be quite appreciable. Normally when we think of a capacitor, we assume that its capacity is dependent purely on physical dimensions, namely the area of the plates, the spacing of the plates and the type and nature of

dielectric or insulation between these two plates. This is partially true in a vacuum tube. However, the input capacity of a vacuum tube varies with the voltage applied to the input grid, and it is here that our difficulty arises.

When the grid bias of an R.F. or I.F. amplifier stage is varied by the A.V.C. control system, the input capacity of the controlled tube changes. As just previously mentioned, this input capacity is part of the tuned circuit. Accordingly, the resonant point of this tuned circuit will shift as the input capacity of the tube in question varies with a change in automatic volume control voltage.

We can now see how, after carefully adjusting our receiver (below the A.V.C. threshold), all this work can be partially nullified due to the effects of the same A.V.C. system which had temporarily been forgotten, or at least caused not to work.

In some receivers this shift in the resonant point of the tuned circuits may not be very serious, but in many cases this factor can assume major proportions. The higher the I.F. frequency, this factor becomes all the more important.

The end results of a shift in the resonant point of the A.V.C. controlled tuned stages are some common troubles such as poor audio quality and distortion due to favoritism towards one of the carrier side bands, increased noise level, reduction in sensitivity, etc.

THE A.V.C. SUBSTITUTION SYSTEM

This Signal Generator overcomes the foregoing alignment defects, by supplying its own A.V.C. VOLTAGE, directly controllable at the front of the instrument panel, from a calibrated A.V.C. voltage substitution network.

By supplying proper A.V.C. voltage to the controlled stages, it is no longer necessary to adjust the Signal Generator for minimum output and set the receiver to the abnormal condition of maximum sensitivity with concurrent noisy operation. This voltage is INDEPENDENTLY adjusted to coincide with the ACTUAL A.V.C. developed by the receiver under normal average conditions of reception. This assures more efficient tuned circuit adjustments as compared to a receiver aligned without the use of the A.V.C. SUBSTITUTION METHOD.

The use of the A.V.C. substitution method is purely optional though it is to be recommended, especially in adjustments on SUPERHETERODYNE receivers incorporating either single or dual automatic volume control circuits. If the operator does not desire to employ it, the setting of the "A.V.C. CONTROL" of the Series E-200-C in no way affects the application of this instrument to other means of receiver alignment.

To employ the "A.V.C. Substitution" method merely examine the receiver circuit diagram for the location of the main A.V.C. voltage lead associated with the diode detector and the A.V.C. load resistor. Disconnect this lead, as indicated, at the point "X", in the diagram previously referred to, and in its place feed the "A.V.C. VOLTAGE" leads in proper polarity, as shown; positive (+) side to chassis or "ground" of receiver and negative (—) side to the grid bias returns or (in the case of dual A.V.C.) to the negative side of the A.V.C. voltage division resistance network. The direct reading "A.V.C. CONTROL" is then set to the required voltage.

"What is this required voltage?" There is no single accurate answer to this question, inasmuch as the actual voltage developed by the A.V.C. system varies with the receiver design as well as with the strength of the input signal. For many receivers, it may vary (under conditions of local station reception) from about 7 to approximately 25 volts in accordance with the aforementioned condition. Under conditions of no signal or very small signal, the minimum bias may be as low as one or two volts. Hence, you may state "How am I to determine where to set the A.V.C. control? And if the A.V.C. voltage in a receiver can vary so much under actual operating conditions, what am I to gain by employing A.V.C. substitution?" The answer is very simple . . .

Let us assume we have a receiver wherein the minimum bias on the A.V.C. controlled stages is about two volts. In other words, this is the effective FIXED bias on the I.F. and R.F. stages when no signal or only a very minute signal is being received. Now let us take this same receiver and see what happens when it is being employed for the reception of normal local broadcast stations, at which time the set owner desires maximum fidelity.

Under conditions of normal reception, this receiver may very well develop 20 volts grid bias in the A.V.C. circuit, or a variation from small signal conditions of 20/2, a ratio of 10 to 1. Had the same receiver been adjusted with the A.V.C. substitution network set for a fixed bias of anywhere from 10 to 20 volts, the ratio between the voltage at which the receiver was aligned (about 15 volts), and the voltage actually developed under normal conditions of reception (about 8 to 20 volts), would be exceedingly small. So we can readily see that it is not so important to have an EXACT fixed voltage substituted for the receiver A.V.C. network, but rather merely a voltage SOMEWHERE NEAR the actually developed A.V.C. voltage.

It is therefore not necessary, as well as being practically impossible, to present "A.V.C. CONTROL" setting data, individual to all receivers. The classifications and settings given are therefore quite arbitrary, but as just previously discussed, need not be more than this.

RECEIVER CLASSIFICATION	Approximate A.V.C. Control Setting
1. Poor sensitivity; extremely low gain; designed primarily for local broadcast reception.	5 to 10
2. Moderate sensitivity; increased allowing for reliable extended broadcast band reception.	7 to 15
3. High sensitivity; excellent overall gain allowing for reliable extended fairly reliable short-wave and long distance broadcast reception with minimum fading defects.	10 to 20

There are other methods by which A.V.C. receivers can be efficiently and accurately aligned. However, not only does the method, just outlined, allow the operator to obtain desirable alignment accuracy, but also simplifies the alignment process BECAUSE: critical signal generator and receiver adjustments have been eliminated; in addition, the operator can employ an ordinary rugged A.C. output meter as his resonance indicating device, rather than more costly and delicate devices.

While on the subject of resonance indicators, it would be interesting to briefly treat this phase of the alignment problem. In the following chapter we shall review some of the more popular methods for obtaining an indication of circuit resonance.

RESONANCE INDICATORS

1.—The simplest and most practical form of resonance or peak output indicator is a rectifier type A.C. meter, such as contained in A.C.-D.C. multi-range testers or combination tube and set testers.

An indicator of this type is connected with a series blocking condenser (about .1 mfd. 600 W.V.) between plate and ground of the audio output stage, or if the audio output stage is of the push-pull type, it is then connected either from plate to plate, or else between one plate and ground. When so connected, the output meter is across a comparatively high impedance, and hence the audio voltage may assume relatively high values. It is therefore necessary that the meter employed be set initially, for the protection of the meter, to a range approximating at least 50% of the D.C. voltage appearing at the plate terminal of the output tube.

An A.C. output meter can also be connected directly across the voice coil terminals of the loud speaker. Inasmuch as voice coil impedances run considerably lower (about .3 to 15 ohms) than those encountered in the previous case, the voltages to be met with are proportionately of much smaller magnitude. Accordingly, when the operator employs an output meter across the voice coil, it will not be found neces-

sary to set the A.C. meter to ranges any higher than about 3 to 12 volts AND a blocking condenser is NOT required when the voice coil winding is isolated from the tube D.C. voltages, except in some special circuits involving inverse feedback via series connection with the speaker output winding.

Inasmuch as the output meter is connected to the *audio* amplifier, a MODULATED R.F. signal is required so that the detector can deliver an audio signal voltage to the amplifier circuit proportional to the R.F. circuit adjustments. Therefore, all trimmers and padders are adjusted until a peak indication is obtained on the output meter.

One note of caution: always keep the R.F. input signal at a point whereat none of the stages of the receiver is ever overloaded.

When using an A.C. output meter with receivers employing A.V.C., it is necessary (if not using the A.V.C. substitution method) to operate with SMALL signal generator output to keep below the point where A.V.C. action levels off the receiver response. Otherwise a broad selectivity curve results, with consequent difficulty in obtaining correct peak adjustment of the trimmers, as described on page (5).

In this connection it may have been the reader's problem to have noted that when using other types of Signal Generators, with the output set below the A.V.C. threshold, there was not enough audio voltage appearing at the amplifier output stage to properly swing the output meter. Such difficulty is usually a matter of insufficient audio component, or too little modulation of the carrier, which generally had been fixed at approximately 30%.

It is in cases such as these that the high modulation percentage capability of the Series E-200 and E-200-C is of particular advantage. Simply raise the modulation to the level required for good output meter indication on the lowest output meter range employable. In this manner, although the R.F. signal intensity can be readily maintained below the point at which A.V.C. action takes place, THE AUDIO COMPONENT OF THE CARRIER CAN BE INCREASED BY OVER 300% and naturally the audibility or utility of the R.F. test signal is proportionately increased. See page (20).

Because of variable modulation percentage, as well as the A.V.C. substitution system, incorporated in the E-200 Series, the simple A.C. output meter need be the ONLY one used for all cases of A.M. receivers, making for standardized alignment procedures.

Other types of resonance indicators may, of course, be employed, but the previous means is by far the simplest. A few of the other methods include the following, and as will be noted, make use of an *unmodulated* R.F. test signal.

2.—The reader is, by this time, familiar with the basic theory of automatic volume control. The A.V.C. voltage

developed in the second detector circuit, is directly proportional to the intensity of the R.F. signal voltage to which the receiver is tuned. Hence, the relative magnitude of the A.V.C. voltage should be a good means of determining when the various receiver circuits are properly aligned. Any device that will indicate the relative value of the A.V.C. voltage, WITHOUT SERIOUSLY DISRUPTING THE A.V.C. CIRCUIT, can be employed.

The A.V.C. diode load resistor may be anywhere from 100,000 ohms to 2 megohms. The measuring device for a resonance indicator should be either a vacuum tube voltmeter or high sensitivity (20,000 ohms per volt) multi-range meter. In this connection there is another valuable point to consider. If the receiver incorporates a TUNING EYE, this tube is actually a form of vacuum tube voltmeter and is already bridged directly across the A.V.C. circuits, for resonance indications. In this case the eye may be adjusted for MINIMUM shadow, whereas the V.T.V.M. or multi-range meter is adjusted for MAXIMUM indication.

3.—If a receiver employs a power detector in the form of a triode or pentode, a V.T.V.M. or 20,000 ohm per volt multi-range meter may be used to measure the D.C. voltage developed across the cathode load resistor. This voltage is also proportional to the intensity of the R.F. input to the detector.

4.—Inasmuch as the R.F. and I.F. amplifier tubes in A.V.C. controlled receivers have their grid bias directly controlled by the voltage developed in the diode detector circuit, the plate current, or for that matter, the cathode or screen current of the R.F. or I.F. stages also varies in direct proportion to the degree of alignment. A D.C. milliammeter in the plate, screen or cathode circuit of one of the A.V.C. controlled tubes may be employed as the resonance indicator. In such case adjustments are made for MINIMUM meter swing. The reason for this is quite obvious when it is understood that the stronger the R.F. signal, the greater will be the A.V.C. voltage. Consequently the greater will be the negative bias on the controlled stages, and along with a greater negative bias comes a decreased amount of current in the various tube circuits. The D.C. milliammeter can be one of the low current ranges of your A.C.-D.C. multi-range meter.

5.—If the A.V.C. controlled tubes employ a fixed minimum bias resistor in the cathode returns, a low range, high resistance voltmeter can be connected across any one of these fixed bias resistors. Since the cathode current DECREASES with increased R.F. signal (due to A.V.C. action), the voltage developed across the cathode bias resistor will also decrease, and we would adjust trimmers and padders for MINIMUM voltmeter swing.

6.—There are some receivers which employ tuning meters rather than tuning eyes. These tuning meters in most cases

fall into the category of paragraph 4. Inasmuch as these meters are usually mounted upside down (which automatically reverses the indications), the meter is tuned for greatest swing, but which in reality corresponds to MINIMUM current.

Other means for obtaining resonance indications might be listed, for there are many things that happen in a receiver that can be employed as indications of resonance. However, the foregoing should be sufficient to satisfy most requirements.

Once having decided upon the type of resonance indicator you wish to employ, it should be connected accordingly and receiver circuit adjustments begun, always working AWAY from the detector stage in T.R.F. circuits and from the second or third detector in single or double superheterodyne types.

TUNED R.F. RECEIVERS (without A.V.C.)

In receivers of the T.R.F. variety (and no A.V.C.), the signal generator coaxial output cable leads are connected to the antenna and ground posts of the set with the appropriate series resistor, condenser, inductance or combination as suggested in the set manufacturers' instruction sheets.

Ground the receiver (with blocking condenser if necessary) to a cold water pipe or other reliable ground. Make the first alignment at the high frequency end of the broadcast band, generally at about 1500 or 1600 kilocycles and with 400 cycle internal modulation. The receiver volume control should be kept at the maximum position. Use the smallest R.F. signal and modulation intensity required for good output meter deflection. Both the Signal Generator and the receiver tuning dials should be set to the same frequency. The shunt trimmer condensers are then individually adjusted for maximum output and the R.F. signal input from the Signal Generator should be progressively reduced to keep the output meter pointer on the scale. The receiver volume control may also be reduced if it is found desirable. After all trimmer adjustments have been made, the process should be repeated to assure correct alignment at whatever frequency has been selected for the test.

Inasmuch as it was previously stated that circuit adjustments should always be in such order that the operator is working AWAY from the detector, the first trimmer to be adjusted therefore, is the one which is in parallel with that section of the ganged tuning condenser which tunes the detector coil. The next trimmer to be adjusted is the one which is across the R.F. amplifier coil immediately preceding the detector, and so on back to the trimmer across the secondary of the antenna coil.

Adjustments of the antenna series compensating condenser (if any) need not be performed until the receiver is installed in the customer's home, inasmuch as the purpose of this con-

denser is to compensate for varying antenna lengths and conditions.

In the event that the T.R.F. receiver, being aligned, uses slotted end-plate tuning condensers, adjustments may also be made at the low frequency end of the dial. Set signal generator and the receiver tuning dials to the same frequencies (this time about 600 Kc), and bend the slotted end-plates in or out for maximum output meter indications. This procedure may be repeated at a few points on the dial, each time adjusting the appropriate slotted end-plates. Some receivers make use of adjusting screws for movement of these end-plates.

TUNED R.F. RECEIVERS (with A.V.C.)

If the T.R.F. receiver being aligned incorporates automatic volume control, there are three basic methods of attack, the second of which is the most economical and simple in apparatus and operational requirements, and yet assuring positive results; this is the "A.V.C. Substitution Method" previously described.

Method 1. Keep the R.F. signal at a level below that at which A.V.C. action takes place, and increase the modulation percentage to the point where a good output meter reading is obtained.

Aside from keeping below the A.V.C. threshold, the actual process of alignment is the same as outlined for T.R.F. receivers without A.V.C.

This method, with T.R.F. receivers, is capable of good results due to the comparatively broad tuning of such radio sets. The following methods eliminate the need of keeping the input signal at such small level as to be below the point at which A.V.C. takes hold.

Method 2. Open the common A.V.C. lead (as described on page (8)), which supplies the bias to the R.F. amplifier grids, and obtain the appropriate fixed negative potential from the A.V.C. substitution pin jacks.

A strong signal, in keeping with actual local receiving conditions, may now be employed and alignment may then be accurately attained without undesirable A.V.C. leveling action. The actual modulation level and R.F. signal intensity required for good initial output meter deflection are dependent entirely upon the original degree of misalignment or mistracking, and the overall gain of the receiver. The R.F. input signal should be reduced as the tuned stages are individually brought into adjustment.

Method 3. This third method makes use of resonance indicator #2 as outlined on page (9) and requires a high resistance voltmeter (20,000 ohms per volt) or V.T.V.M. to measure the actual A.V.C. voltage developed. Adjustments are made until a peak reading is obtained, inasmuch as

maximum A.V.C. voltage coincides with resonance. An UNMODULATED signal is utilized with this method of alignment, whereas in the two previous methods, a MODULATED signal is employed, inasmuch as a simple audio output meter was utilized as the medium of resonance indication. If a modulated signal is used with this Method 3, the audio tone would merely serve for the purpose of audible signal identification.

SUPERHETERODYNE RECEIVERS

The superheterodyne presents different alignment problems than those of the T.R.F. receiver, though actually none the more difficult when instructions are followed and a basic understanding of the superheterodyne principle is possessed. Even the additional features of A.V.C. (Automatic-Volume-Control) and A.F.C. (Automatic-Frequency-Control) are easily handled when one acquires a knowledge of the fundamental principles.

A few seconds spent in roughly reviewing the superheterodyne principle would be in order, at this moment.

Reference to the block diagram below reveals that a superheterodyne consists essentially of an R.F. signal amplifier, a local oscillator, a mixer (often referred to as the first detector), an intermediate frequency amplifier, a second detector and then the usual audio amplifier and loud speaker. The main idea of the superheterodyne principle is that the signal from the antenna or R.F. amplifier is caused to beat against a locally generated signal, in the first detector or

mixer. The resultant frequency caused by the "mixing" or beating together of these two signals is then passed along into the I.F. amplifier. The receiver is so designed that there is a very definite relationship between the incoming signal and the frequency of the local oscillator. The actual difference in frequency between the two is the resonant frequency of the intermediate frequency amplifying system. The I.F. amplifier is nothing more or less than a fixed-tuned R.F. amplifier with excellent selectivity and gain characteristics for operation at the one selected frequency.

Because of the fact that the intermediate frequency amplifier coils need only perform at one frequency, these coils can be designed for high efficiency and with excellent selectivity. It is because of this conversion of the incoming signal to the intermediate frequency and further because of the excellent characteristics of I.F. amplifiers, that the superheterodyne is able to give such favorable results on both the crowded broadcast and short-wave bands and with minimum adjacent station interference.

Once the converted signal has entered the I.F. amplifying system, there is no longer any great difference between a superheterodyne and a T.R.F. receiver. The I.F. signal is amplified, then demodulated and then passed to the regular audio amplifier.

ALIGNING THE SUPERHETERODYNE

The first step in the alignment of a superheterodyne (regardless of whether it incorporates A.V.C. or not), is the

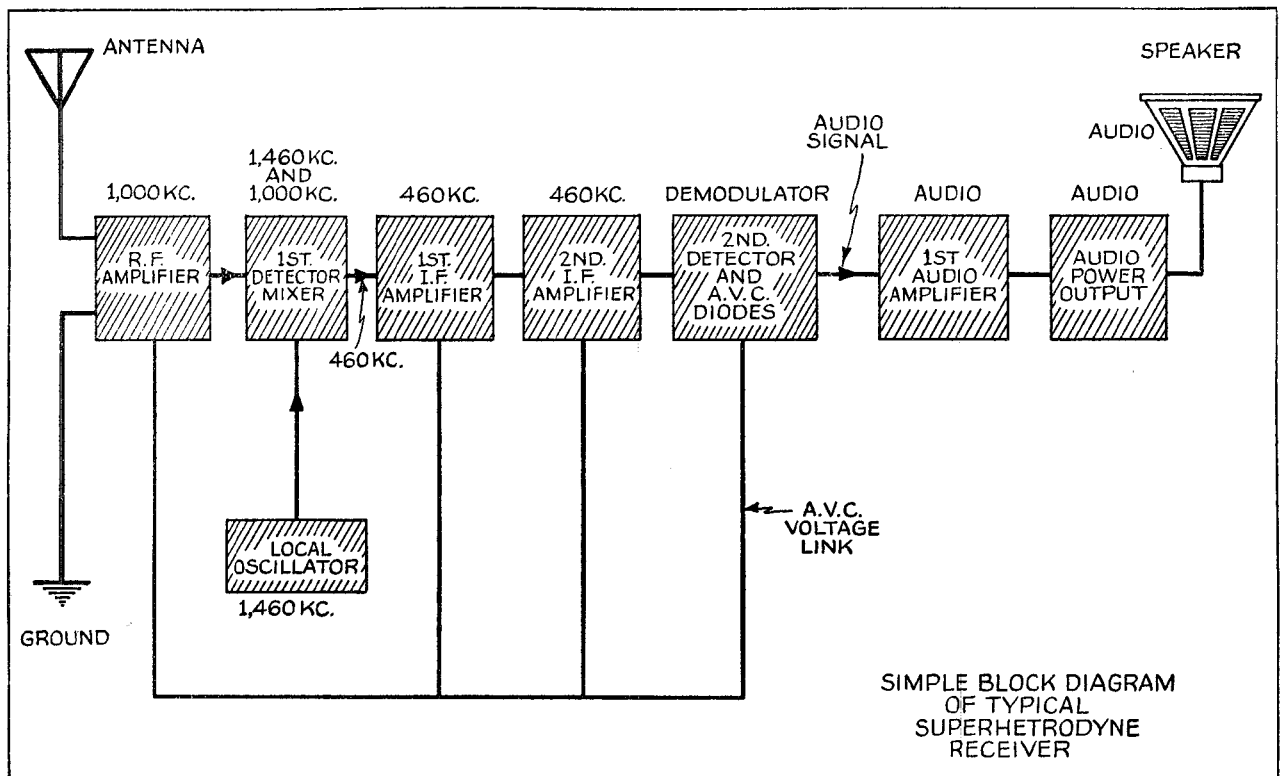

alignment of the I.F. amplifier. If the receiver to be aligned incorporates a *selectivity* control (variable I.F. band width) in the form of a "Narrow, Normal, Wide" switch or some similar type, it is necessary that this control be rotated to the maximum selectivity (Narrow) position before any adjustments are made. Next, and this is very important, to prevent interference (unwanted beat notes) from the local oscillator of the receiver, it is imperative that the operator short circuit the oscillator section of the condenser gang. This may be done merely by using a short double clip lead from rotor to stator or stator to ground. Use a .002 to .01 mfd. fixed condenser in series with the jumper lead just mentioned.

As in the case of the T.R.F. receiver, the actual basic alignment method and means of resonance indication are optional with the operator; though with the presence of A.V.C. (more so in a superheterodyne than the T.R.F. receiver), it is desirable that the service technician choose alignment method either #2 or #3 previously outlined on page (9).

For the alignment of the I.F. system, the receiver band switch (if any) should be set to the broadcast band position, so as not to place a low impedance short-wave coil between the first detector grid and ground. The BLACK lead of the coaxial output cable should be connected to the receiver chassis and the receiver chassis tied to a good external ground. If the superheterodyne does not incorporate A.V.C., it is not always necessary to employ a blocking condenser in series with the RED output cable lead, unless otherwise directed in the manufacturers' service notes. However, if A.V.C. is incorporated, it is quite desirable to use a blocking condenser in series with the RED lead so that there is no D.C. return to the test oscillator's attenuation circuit which would disturb the operating characteristics of the receiver by shorting out the A.V.C. voltage or fixed minimum A.V.C. bias. The RED lead (through its blocking condenser), is then connected to the grid of the first detector.

The Signal Generator dial should be set to the specified I.F. frequency, using the smallest R.F. signal and modulation level in keeping with good output meter deflection. If aligning below the A.V.C. threshold, the receiver volume control should be at maximum position, because of the small test signal employed. However, if you are operating with A.V.C. Substitution or measuring A.V.C. voltage as the means of resonance indication, the receiver volume control can be set to any convenient position.

Begin the I.F. trimmer adjustments at the second detector and work back towards the first detector, repeating adjustments to make sure that interaction effects between the primaries and secondaries of the I.F. transformers have been mutually compensated.

There is always the possibility that the I.F. amplifier may

be so badly out of line that an output meter deflection cannot be obtained even with maximum settings of all signal generator and receiver controls. In such event (though not very common), it would then be necessary to inject the I.F. signal into the grid of the last I.F. stage and work back stage by stage. The first detector is then the LAST tube to receive the I.F. signal.

The choice of a resonance indicator will determine whether it is necessary to use a modulated or unmodulated signal. With some types of indicators, namely, those wherein the reading is dependent on the A.V.C. system, it is not required to work below the A.V.C. threshold and any strength of R.F. signal that does not overload the receiver, may be employed. This is the very purpose of the A.V.C. Substitution System, thereby insuring easier alignment as well as better normal local reception.

Having completed the I.F. amplifier alignment, the RED and BLACK output leads of the signal generator are connected to the antenna and ground posts of the receiver and we then prepare for Oscillator, R.F. stage and first detector adjustments. An appropriate DUMMY ANTENNA should be inserted between the receiver antenna post and the signal generator RED lead, whenever manufacturers' service instructions suggest same. REMOVE THE SHORTING LEAD PREVIOUSLY PLACED ACROSS THE OSCILLATOR TUNING CONDENSER. Keep the receiver selectivity control at maximum selectivity position and the gain control in the same position as it was in the previous operation.

Set both receiver dial and the signal generator to the high end of the broadcast band, generally about 1500 Kc. If the tuning condenser uses a special oscillator tracking section, there may possibly be no adjustment that can be made to the oscillator circuit other than (ONLY IF ABSOLUTELY REQUIRED) bending of the slotted end-plates of the tracking section. In general (except in small-sized, very low-priced receivers), this is not the case and the oscillator parallel trimmer screw is slowly turned until the signal is heard. Then carefully adjust it for maximum output-meter deflection. The first detector (and R.F. stage if any) parallel trimmers are then also tuned for maximum indication. This temporarily concludes the adjustments for the high frequency end of the band.

Next, the receiver and Signal Generator are set to the low end of the broadcast band, generally about 600 Kc, and the oscillator series padding condenser is adjusted by "rocking"* (see note below) for maximum output meter

*NOTE: The oscillator alignment procedure, referred to as "rocking," merely consists of finding that combination of oscillator low frequency padder adjustment and receiver tuning dial position which gives maximum output regardless of whether the receiver tuning dials falls exactly on the 600 Kc spot or not. In this manner, the receiver is adjusted for maximum operating efficiency.

indication and when necessary, the R.F. and first detector tuning condenser end-plates are adjusted. The high frequency adjustments should then be repeated to assure best results. Bear in mind that the signal generator output should be reduced when the output meter indications increase with alignment, to prevent slamming of the meter pointer.

When the receiver is of the multi-band type, the next adjustments are made on the other bands, in accordance with the procedure outlined above.

The I.F. circuits are no longer touched. The R.F. stage, detector and oscillator trimmers and the low frequency oscillator padders (if any) are the only units to be adjusted for each individual band. First select a frequency at the high end of the band and then one at the low portion of the dial.

At times, with receivers using pentagrid converters (combination of first detector and oscillator), there may be some interaction between oscillator and first detector trimmer adjustments at the high frequency end of the bands. In cases such as this, the "rocking" process previously described should be applied even at the high end of the band to find that combination of oscillator and first detector parallel trimmer adjustments which offer best operating efficiency.

The foregoing *generalized* alignment procedures are not meant to supplant more specific manufacturers' service notes which should ALWAYS be consulted before attempting to adjust the tuned circuits of a receiver; especially those receivers incorporating automatic frequency control. The use of the A.V.C. Substitution method does not interfere with manufacturers' instructions, but merely serves to simplify the alignment technique. The foregoing information is, however, sufficiently complete to allow the operator to proceed with receiver alignment in the absence of specific data.

AUTOMATIC FREQUENCY CONTROL CIRCUITS

The adjustment of A.F.C. circuits differs to some extent in various receivers, and hence no specific details are given here, but rather just a general idea of the points behind A.F.C. circuit alignment. At the same time, it would be well to state that automatic frequency control is not popularly employed in broadcast receivers and it is therefore not very probable that many technicians ever encounter such a receiver circuit. Broadcast receiver manufacturers have generally chosen a more simple and economical solution to the problem of tuned circuit stability in the form of highly stable air-tuned trimmers, silver-mica condensers, as well as temperature compensating condensers.

For A.F.C. adjustment, the signal generator is set to the exact I.F. specified in the manufacturers' manual so that the frequency control network may be caused to function uniformly on both sides of the resonance curve. A high resistance voltmeter or V.T.V.M. is connected across the two

cathodes of the discriminator tube, such as a 6H6, and the necessary trimmer adjustments are made (in accordance with manufacturers' instructions) to give zero voltage reading. When this is obtained, the discriminator has been BALANCED for proper operation; assuming the I.F. amplifier is of course also aligned for optimum performance, at the SAME frequency at which the discriminator tube has been balanced.

It is of utmost importance that manufacturers' service notes be closely followed for proper A.F.C. circuit alignment and that the I.F. stages and discriminator definitely be aligned AT THE SAME INTERMEDIATE FREQUENCY.

This does not mean that you must have crystal accuracy in the setting of the frequency chosen. All that this means is that the Signal Generator dial should not be moved when making the discriminator tube and I.F. stage alignment. In other words, as long as the discriminator and I.F. stages are aligned at the SAME frequency (regardless of whether this frequency may be a little above or below the specified frequency), no trouble will be experienced. In short, a circuit specified as having an I.F. of 460 Kc can be aligned just as accurately at 465 or 455, so long as the entire series of inter-related circuits are also aligned AT THAT FREQUENCY.

THE ADJUSTMENT OF FREQUENCY MODULATION RECEIVERS

The long-familiar system of amplitude modulation operates on the principle of CONSTANT carrier FREQUENCY and the amplitude of the carrier is varied in direct proportion to the intensity of the sound picked up by the microphone. The frequency of the sound delivered from the microphone to the transmitting equipment basically merely determines the rate at which the AMPLITUDE of the carrier is varied.

In a frequency modulated signal the AMPLITUDE of the carrier remains essentially CONSTANT, and with modulation, the carrier frequency shifts symmetrically about the mean carrier frequency. In other words, the intensity of the sound picked up by the microphone directly determines how much the original frequency of the carrier will be shifted. This carrier shift (which is equal on both sides of the unmodulated carrier frequency), determines what is referred to as the BAND WIDTH. Therefore, let us assume that the carrier frequency is 90 megacycles and the transmitter is so designed that 100% modulation corresponds to a symmetrical frequency deviation of 75 Kc. The total band width of the transmitted signal is then fundamentally 75 Kc ABOVE and BELOW the average frequency of 90 megacycles, or a band width of 150 Kc.

It is not important to burden the reader with the technical details of why a band-width of approximately 100 to 200 Kc was chosen. Suffice it to say that by selecting sufficient

band-width, desirable signal to noise ratios are obtainable. However, along with this wide-band transmission, comes the consequent necessity of transmission at carrier frequencies which are considerably higher than those associated with the regular broadcast band.

Frequencies between 40 and 44 megacycles were originally temporarily chosen and today F.M. is located in the range of 88-108 Mc. The final frequency selection involved factors such as decreased effects of atmospheric and man-made disturbances, as well as desirable radiation characteristics for local coverage, etc.

We have noted that carrier FREQUENCY DEVIATION is proportional to the INTENSITY OF MODULATION. The frequency of the modulating sound determines the rate at which the carrier shifts frequency. To elaborate, let us assume the same 90 megacycle carrier is to be modulated 100% by a 100 cycle tone. The transmitter in question creates a deviation of plus and minus 75 Kc at 100% modulation. Now, inasmuch as a 100 cycle note is causing the modulation, the carrier frequency (considering only one half of the band width) is then shifting from 90 megacycles to 90 Mc plus 75 Kc and back again, 100 TIMES A SECOND. If a 1000-cycle note was the modulating tone, this would happen 1000 times a second.

Inasmuch as we are now involved with special transmission characteristics, a special receiver, or at least a special tuner is required, capable of covering the 88 to 108 megacycles spectrum. Furthermore, it must tune with reasonably uniform response over a band width of 100 to 200 kilocycles. In addition, since a frequency modulated carrier is essentially of CONSTANT AMPLITUDE, means must be provided in the receiver to overcome the effects of fading, sharp noise impulses or other forms of transient interference which are in the category of amplitude variations.

Still further, the receiver must provide a method for converting the carrier frequency deviations back into the same

audio sounds which were originally responsible for their creation.

On this page will be found schematic of a typical frequency modulation receiver.* Reference to this schematic will reveal that there is nothing very unconventional about the circuits of the first detector, oscillator and I.F. stages, except for the fact that loading resistors have been placed across the R.F. and I.F. secondaries. These resistors (in addition to special transformer design), allow the transformers to accommodate the 100 to 200 Kc band-width.

The gain of these I.F. stages, with conventional old style tubes, would be quite small. However, the use of specially developed high-gain R.F. pentodes makes up for the loss of gain that would otherwise occur.

Following the intermediate frequency amplifier stages, we find what is referred to as the LIMITER tube. This limiter section of the receiver may, in other receivers, assume more complex forms, however, the fundamental purpose will nevertheless be the same. The limiter tube is so designed that it will pass THE INTERMEDIATE FREQUENCY and its modulation components, but due to special circuit characteristics the limiter keeps the output I.F. signal amplitude at constant level. The A.V.C. properties of this stage are consequently responsible for the reduction of the undesirable effects of fading or noise, which primarily appear in the form of changes in amplitude. If serious variations in amplitude were permitted to pass this point of the receiver, distorted reception would occur.

Following the limiter stage, we find what is equivalent to the second detector in normal A.M. superheterodynes. This detector or DISCRIMINATOR, as it is called, develops in its output circuit, an A.F. voltage which is directly proportional to the DEVIATION of the frequency modulated carrier.

*The sound section of a modern TV. receiver is basically similar to a straight F.M. receiver.

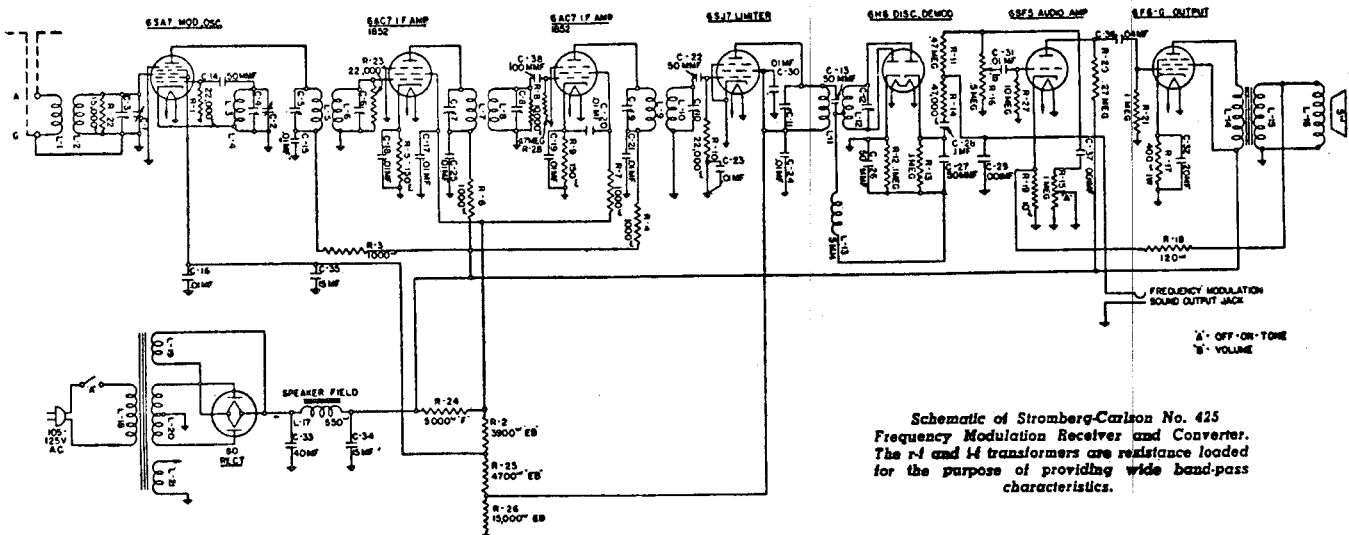

Schematic of Stromberg-Carlson No. 425 Frequency Modulation Receiver and Converter. The r-1 and r-4 transformers are resistance loaded for the purpose of providing wide band-pass characteristics.

Close inspection will reveal that this discriminator is the same as the discriminator stage associated with automatic frequency control circuits and operates in the same manner: . . . the output appearing in the dual cathode circuit is proportional to the CARRIER DEVIATION. The rest of the receiver, which is the audio amplifier, requires no additional comments except for the fact that the audio amplifier systems of frequency modulation receivers should be designed to give much better audio frequency response than is usually associated with every day A.M. radio sets in order to take advantage of the higher fidelity characteristics possible with F.M.

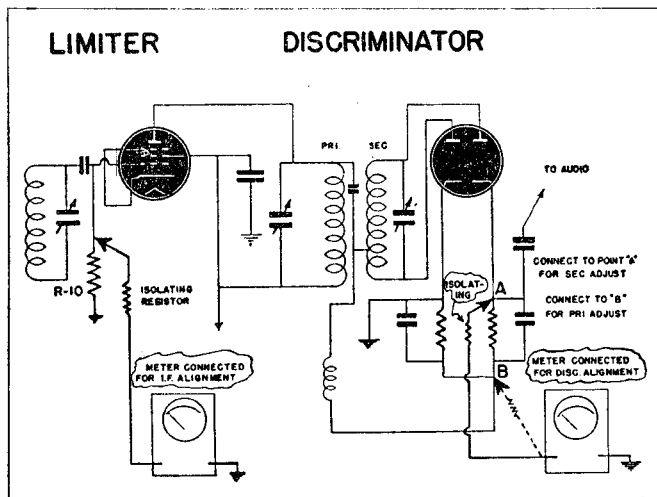

F.M. receivers can be satisfactorily aligned using just an A.M. Signal Generator as the signal source OR through use of Visual Alignment equipment.

The A.M. method is a straightforward PEAKING procedure, similar in approach to the usual AM alignment techniques. In well-designed F.M. receivers, the simple peaking procedure produces satisfactory results. However, VISUAL methods (using a Sweep Generator and Oscilloscope), do offer time-saving advantages. (See Page 16)

The standard A.M. method can be applied to any F.M. receiver provided the operator follows the set manufacturer's instructions very carefully. However, whenever possible, overall performance should nevertheless be double-checked via Visual methods as this will most rapidly and accurately demonstrate the final results.

The first step in the adjustment of F.M. receivers is the alignment of the discriminator circuit and in this connection may we call your attention to page (13) which deals with the adjustment of automatic frequency control circuits. The same considerations mentioned at that point apply here. In other words, it is absolutely essential that the discriminator

tube and the I.F. stages be adjusted at EXACTLY the same frequency.

The I.F.'s of F.M. Receivers may run somewhere between 4 and 15 megacycles*. The only additional requirement that the adjustment of F.M. I.F. stages imposes is that the Signal Generator employed be adequately stable, and with this thought in view, the Series E-200 and E-200-C admirably fill the bill.

To proceed:—connect the coaxial output cable leads between grid and ground of the limiter tube, and as in the case of the A.F.C. discriminator, a 20,000-ohms-per-volt multi-range meter or a V.T.V.M. is connected across two cathodes of the discriminator. An UNMODULATED test signal is employed and the Signal Generator dial is set to the I.F. specified in the manufacturers' data sheets. Then, just as with the A.F.C. discriminator, the primary and secondary trimmers of the discriminator transformer are adjusted until ZERO VOLTAGE is read on the meter scale.

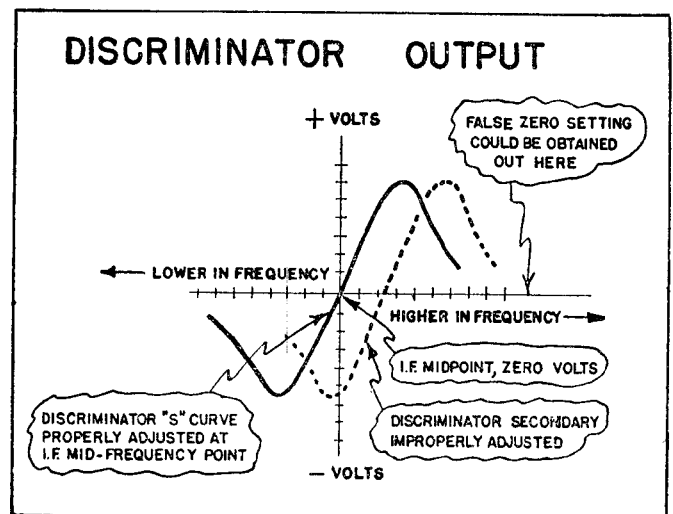

It should be noted that adjustment of the primary of discriminator transformers will control the MAGNITUDE of the secondary output. Adjustment of the SECONDARY will vary the center or mean frequency of the discriminator "S" shaped response curve.

Should the secondary of the discriminator transformer happen to be at its proper midpoint adjustment, zero voltage will be obtained at the output of the discriminator. Under these conditions the secondary must FIRST be DETUNED to yield a voltage reading (either positive or negative) at the output of the discriminator BEFORE primary adjustment can be made. Adjustment of the primary can now be made to produce a maximum voltage reading at the output of the discriminator. AFTER this adjustment is completed the secondary is readjusted to yield a zero voltage indication.

*Higher in sound sections of split channel TV receivers. Usually 10.7 Mc in straight FM receivers and 4.5 Mc in Inter-carrier type TV receivers.

The operator can avoid this temporary detuning procedure by taking advantage of the fact that voltage is developed across ONE HALF of the discriminator load network even when the discriminator secondary is properly adjusted. This fact permits an ALTERNATIVE procedure for aligning the PRIMARY of the discriminator transformer, as follows.

Connect the V.T.V.M. or 20,000 ohms per volt multimeter to the JUNCTION of the two discriminator load resistors and ground. With the generator set to the I.F. frequency, a reading will be obtained on the V.T.V.M. (even if the secondary happens to be at proper midpoint adjustment). The discriminator primary winding is then adjusted for maximum meter reading. The meter is then re-connected across the cathodes of the discriminator tube and the SECONDARY winding is adjusted for zero voltage as previously described.

Care must be taken to avoid setting the discriminator secondary to a FALSE zero setting. For example, the secondary trimmer could inadvertently be set to zero voltage at the right or left of the positive or negative peak of the discriminator "S" response curve. To test for the proper zero setting, the operator should vary the secondary trimmer setting very slightly to the left and right. With the proper Zero Setting, voltage indications of opposite polarity should be obtained.

Without disturbing the setting of the Signal Generator tuning dial, transfer the coaxial output leads to the grid and ground of the LAST I.F. amplifier tube (closest to the limiter stage).

Disconnect the V.T.V.M. or 20,000 ohms per volt tester from the discriminator. Connect one end of a 25,000 to 100,000 ohm carbon resistor to the high side of the limiter grid resistor (R-10 on the diagram). Connect the V.T.V.M. or 20,000 ohms per volt tester across the free end of the carbon resistor and ground. (Disable the receiver's local oscillator to eliminate false peaks). If the I.F. system is known to be a simple peaked amplifier you need merely adjust both primary and secondary for maximum meter deflection at the specified I.F. frequency.

If the I.F. system is the overcoupled or "double-humped" type, greater care must be taken to obtain the proper I.F. band width. If it were possible to physically separate the two windings of a PROPERLY ALIGNED overcoupled I.F. transformer, each winding would be found peaked at the same specified I.F. frequency: However, when the windings are placed in proper proximity to each other, overcoupling results, producing an overall "double-humped" response curve. In order to perform a simple peaking operation on each winding, of such I.F. transformers, the overcoupling effect must be temporarily eliminated or minimized. This is accomplished by temporarily shunting the primary, for example,

with a 1000 ohms carbon resistor. This resistive shunting or "loading" of the primary permits the SECONDARY winding to be simply peaked at the specified I.F. frequency for a maximum reading on the indicating instrument. After this is accomplished the procedure is reversed, i.e., the secondary is loaded with the resistor and the primary is simply peaked to the same specified I.F. frequency. The resistor is then removed from the secondary, and the inherent overcoupled design of the transformer will then produce the typical double-humped response curve, centering about the specified I.F. frequency.

The output leads of the Signal Generator are then transferred to grid and ground of the preceding I.F. stage and the peaking procedure (using the loading resistor technique in the case of overcoupled I.F.'s) is performed on the next I.F. stage. The procedure is repeated for each I.F. stage until all I.F. transformers have been aligned. The last I.F. adjustment is made with the output of the Signal Generator injected at the R.F. input grid of the first detector or mixer, which in this particular case is a 6SA7.

It is important, in all the foregoing adjustment procedures, to keep the Signal Generator output at as low a level as will permit reasonable V.T.V.M. or high-sensitivity multimeter readings. Excessive Signal Generator output may cause overloading of the I.F. stages, which could result in errors arising from overly broad output meter indications.

It is always helpful to securely interground all test instruments and the chassis of the set being aligned. Simple and positive grounding can be effective through use of an aluminum or copper bench plate.

To re-check the *overall* response of the aligned I.F. system the Signal Generator output should be injected at the mixer input grid. The V.T.V.M. or 20,000 ohms-per-volt multimeter is then connected across the output of the discriminator. With the Signal Generator set to the same frequency at which the I.F.'s were just aligned, the voltage at the discriminator should be zero. However, shifting the frequency of the Generator, 50 to 100 Kc (.05 to .1 Mc) on either side of the specified I.F. should give equal or nearly equal meter readings, but at opposite polarity.

Another way to test for symmetrical response is to connect the meter across the limiter grid resistor and note the change in meter reading while the generator tuning dial is moved to 100 Kc on either side of the specified I.F. Approximately the same change in meter reading should occur on both sides of the specified I.F. frequency.

If reasonably approximate symmetry does not occur, each of the I.F. stages should be again adjusted, because good F.M. receiver audio performance depends upon the best POSSIBLE symmetrical response of the I.F. and discriminator circuits.

If a Sweep Generator and Oscilloscope are available, the re-checking procedure is less time-consuming inasmuch as the result of the alignment procedure becomes instantly evident on the 'scope screen. Reference should be made to the Sweep Generator Instruction manual for the details of Visual alignment and check of overall response curves.

Before proceeding to adjustment of the rest of the F.M. receiver, it is interesting to note that it is not always necessary to attain PERFECT symmetry along the double-hump portion of the I.F. response curve, due to the flattening effect of the limiter stage or stages. In other words the humped portion of the I.F. waveshape becomes "clipped" or flattened by the limiter action at medium to high input levels. From this analysis it can also be seen that the dip between the two humps in the overcoupled I.F. system should not be so excessive as to produce a dip in the center of the curve even AFTER limiting.

The remaining few adjustments are not very critical and are much the same as those associated with the alignment of the first detector and oscillator of regular high frequency bands. The Series E-200 or E-200-C is set in accordance with the receiver manufacturers' service notes to, let us say, 90 megacycles and the oscillator trimmer and R.F. input trimmer adjusted for maximum reading of the resonance indicator which is still a V.T.V.M. or 20,000 ohms per volt multimeter at the limiter grid resistor return. The receiver dial is tuned for the reception of the same frequency at which the Signal Generator is set.

This completes the adjustment of the receiver, however, tuning of an F.M. set is a bit different from the process usually associated with the tuning of receivers designed for amplitude modulated carriers.

When tuning for and approaching an F.M. station carrier, the speaker output will slowly become louder and louder, and in the event that external noises are present, these noises will at the same time be quite discernible. However, continuing the tuning process, a point will be reached whereat the station signal will seem to grow a bit weaker, but simultaneously the noise level will almost automatically and practically disappear. At this point the receiver is properly tuned and if the operator continues to turn the dial, the signal will again appear to increase but with consequent increase in noise level. It is therefore important that the operator or owner of an F.M. receiver be instructed in proper tuning procedure if best results are to be obtained.

If the F.M. receiver incorporates a single or multiple shadow tuning eye, the operator should then tune, per the set manufacturer's instructions, for the required eye pattern instead of tuning by ear.

* * *

The foregoing information was intentionally limited, for the sake of simplicity, to just one type of F.M. receiver circuit, namely those

incorporating a limiter-discriminator following the I.F. section. There are other means employed for demodulating an F.M. transmission, such as the ratio detector. However, once the basic concepts of F.M. receiver alignment are understood and practiced, demodulator type variations present no special complications. Always follow the receiver manufacturer's instruction for the particular considerations he feels will yield the best results for the type of circuit employed.

Inasmuch as the prime purpose of this book is to reveal the fundamental usage of the A.M. Signal Generator, we purposefully do not burden the reader with oscillographic alignment methods which require the additional ownership of a Sweep Signal Generator and a High Sensitivity Oscilloscope. However, suffice it to say that the A.M. Signal Generator is a most valuable tool even when oscillographic alignment procedures are employed. Such details are part of the instructional data which accompanies the Sweep Signal Generator.

* * *

At such time as the reader becomes actually engaged in the use of this additional apparatus, he will become aware of the ever increased importance of a good, stable A.M. Signal Generator such as the E-200 and E-200C.

* * *

TELEVISION RECEIVERS

Although it is possible to align TV receivers via use of only A.M. Signal Generator methods, the extended time, effort and possible complications involved do not warrant detailed instructions to such end.

The nature of TV receiver circuits are such as make it advisable to employ oscillographic means of alignment and adjustment. With this in mind, the reader is directed to his Sweep Signal Generator instruction manual for TV applications. In addition, the operator should more rigidly than ever, follow the set manufacturer's service notes.

When so doing, you will find that certain TV set adjustments permit or prescribe use of A.M. signals. Among the various points involving use of A.M. signals are the following.

1. ALIGNMENT OF THE SOUND I.F. SECTION. Use same general procedure outlined for regular F.M. receivers.
2. ADJUSTMENT OF SOUND SECTION LIMITER-DISCRIMINATOR CIRCUITS. Use same general procedure outlined for regular F.M. receivers.
3. ADJUSTMENT OF TRAP CIRCUITS. Resonate traps in accordance with set manufacturer's details with E-200-C set to prescribed trap frequency.
4. ALIGNMENT OF STAGGER-TUNED VIDEO I.F. STAGES. Treat each stage individually. Set generator to frequency prescribed for that stage. Peak adjust the I.F. trimmers (or slugs) of that stage, for maximum response in similar manner prescribed for A.M. receivers.
5. TV RESPONSE CURVE WAVESHAPE ANALYSIS. The E-200-C, when connected for use as a marker generator becomes an important TV service instrument. The Marker or "Pip" which it superimposes on Video and Sound response curves, permits the operator to set

sound and picture traps, picture carrier midpoint, appropriate video I.F. knee points, and all sound channel I.F. and Discriminator curves. Because the E-200 Series is a continuously variable Pip Generator, all points on Video I.F. and Sound response curves can be checked for waveshape configuration and for bandwidth.

- b) Markers on the Steep portions of a response curve are normally somewhat difficult to discern. Reduce the Sweep Width of the Sweep Generator, thereby "expanding" the portion of the trace to be observed.
- c) Use the "circulating ground current" injection method just described at A (b). Increase the spacing between the E-200-C output cable alligator clips to increase the amplitude of the marker.

MARKER GENERATOR APPLICATION NOTES

A. To connect the E-200-C for use as a Marker or "Pip" Generator either one of the following methods can be used:

- a) Connect the E-200-C output to the Sweep Signal Generator terminal provided for external marker signal injection. Set E-200-C to required marking frequency. Adjust E-200-C output controls (and Sweep Generator marker amplitude control) to yield a visible marker pip on the oscilloscope pattern.
- b) Connect both the "hot" and ground leads of the E-200-C output cable directly to the receiver chassis, spacing the clips approximately 6 to 8 inches apart. Locate the clips on the chassis such as to straddle the Sweep Generator injection point. This method sets up strong circulating ground currents in the receiver chassis which effectively introduces the marker with a minimum of response curve distortion.

B. MARKING DISCRIMINATOR RESPONSE "S" CURVES. The mid-frequency point of a Discriminator or similar F.M. detector is a zero voltage output point. As a result, a marker pip at this point is difficult to discern. If, however, the A.M. Generator is set for "MOD. R.F.," strong modulation "wiggles" will appear at either end of the response curve when the marker locates on any point of the curve EXCEPT the midpoint. As the marker frequency is adjusted to locate at the curve midpoint, the amplitude of the wiggles will decrease reaching a minimum when the marker finally locates AT the mid-frequency point.

C. MARKING SOUND AND PICTURE TRAPS. The method described in (B) may also be used to advantage in the marking of Sound and Picture traps. With the E-200-C set to "MOD. R.F.," the modulation "wiggles" will diminish to a minimum as the marker pip descends into the trap valley.

D. Methods for improving visibility of Marker pips.

- a) Do not use excessively strong Sweep Generator output. Strong Sweep Generator output requires decreased set sensitivity, thus reducing the visibility of the marker.

SPECIAL NOTES

External Modulation of the R.F. Signal

The four position "AUDIO SIGNAL" switch at the lower right hand corner of the Series E-200-C panel provides for modulation of the R.F. signal from an external source, when the switch is set to the "EXT. MOD." position. The "MOD. CONTROL" still determines the actual percentage of modulation, although the settings for the various levels will naturally differ from those given for the internal 400 cycle modulation. This is readily understandable when it is realized that it is highly improbable that the external source of modulation will be of the same peak voltage as that of the internal audio oscillator.

The impedance at the "HIGH" and "GND." pin jacks is approximately 500,000 ohms. Some crystal type phonograph pick-ups furnish adequate output voltage at this load impedance so as not to necessitate pre-amplification. This assumes that no corrective networks are included in the pick-up leads which would tend to reduce the voltage output. Magnetic pick-ups and microphones especially, require previous stages of voltage amplification, in order to bring the signal up to a sufficient intensity to be applied to the "AUDIO SIGNAL" terminals.

Because of the presence of a blocking condenser already in series with the "HIGH" pin jack, direct connection can be made from this terminal to the plate of any voltage amplifier employed, AS LONG AS THE D.C. PLATE POTENTIAL DOES NOT EXCEED ABOUT 350 VOLTS.

0-110 Numerical Scale and Vernier Segment

The 0-110 scale along the upper circumference of the tuning dial, WHEN EMPLOYED IN CONJUNCTION WITH THE TOP VERNIER PLATE, allows for direct numerical readings in tenths of one division, providing 1000 readable points over the range of 0-100. The incorporation of this numerical reference scale, in addition to the direct frequency calibrated bands allows for maximum accuracy in resetting to any desired frequency; in other words, it simplifies the matter of returning to EXACTLY the same dial spot when occasions demand it.

Another use of the numerical scale and vernier is to spot special odd frequencies as may be employed in government, commercial, aeronautical, police, amateur or experimental services. In such cases, the E-200 is tuned to zero-beat against the exact frequency and the dial settings taken directly from the numerical scale and vernier. This reading can then be duplicated at any time, as well as rechecked with the greatest of ease.

When using the 0-110 scale, the ZERO LINE of the vernier plate becomes the reference indicator INSTEAD OF THE RED HAIR-LINES OF THE CELLULOID POINTERS. It will be noted that the 10 divisions on the 0-10 vernier plate are ALWAYS to the right of the 0-110 dial reading. These 10 vernier divisions are equal to 9 divisions on the 0-110 scale, which factor provides the vernier action, that is, allows for reading the numerical scale in tenths of one division. For example:—

Let us assume that for some specific case, the dial number under the vernier ZERO reference mark is somewhere between 28 and 29. Just what that EXACT decimal may be is difficult to ESTIMATE. The vernier plate simplifies this problem. Merely look along the vernier scale and locate that ONE division of the 0-10 scale which most completely coincides (runs into) any one of the dial divisions directly

below. If the seventh line of the 10 division vernier plate is THE one, then the decimal is .7 and the full reading is then 28 plus 7/10 or 28.7. ONE and only ONE vernier division can possibly fully coincide at a time with a dial division except for the two extremes ZERO and 10. When both the zero and 10 coincide, it indicates that the dial reading under the zero mark is complete, that is a WHOLE number, such as 29.0. Therefore according to the theory of the vernier, a number can be read (when both zero and 10 are coincident) as either 29.0 or 28 plus 10/10, which are mathematically identical.

To reverse the procedure, that is, to set the dial according to a given numeral (let us assume 56.4 is desired), merely first set the dial so that the nearest whole number (56.0) falls under the ZERO of the VERNIER PLATE. Then watch the 4th division of the vernier plate and slowly rotate the dial TOWARDS the 57 mark, but STOPPING as soon as the .4 line on the vernier plate coincides with one of the dial divisions below it. This will occur before the dial reaches the 57 mark.

Instrument Service

It will be noted that in order to remove the E-200 from its metal carrying case, it is necessary to remove the 12 panel border screws AND THEN the two chassis retaining screws at the rear of the cabinet. When removing the instrument from its housing, extreme care should be exercised to prevent hitting any of the internal components against the overlapping mounting surfaces of the cabinet. The same should be observed when placing the chassis back into the cabinet.

If at any time this instrument should fail to function properly, tubes should always be tested first and replacement, if necessary, be made with the EXACT SAME TYPE NUMBERS.

If the instrument does not function at all, check the fuse and when required, replace with equivalent type 1 ampere type 3AG.

The schematic diagrams included with this manual may prove of assistance in the location of possible simple difficulties. However, bear in mind that our factory service division is best equipped to render efficient assistance in the performance of any and all repairs or adjustments.

Should it become necessary, at any time, to return your E-200 or other Dynascan equipment for repair, recalibration or adjustment, same should be carefully packed in an oversized carton and forwarded via Railway Express Prepaid. This manner of handling will insure promptest possible and most satisfactory service.

IMPORTANT NOTE
RELATIVE TO SERIES E-200-C and E-200
MODULATION CONTROLS

On page (4) of this book reference is made to setting of the "Modulation Control".

In models PREVIOUS to E-200-C this control is NOT direct reading in terms of percentage of modulation, instead, the settings MUST be made in accordance with the approximate settings chart which appears below. This chart lists internal modulation percentage versus "Modulation Control" settings and should be followed for best results.

If this control be set above 6.5, or above 100% modulation, the modulation tone may cut off as if the control were open. This is a direct result of overmodulation and is NOT a defect of the instrument.

The audio sections of Series E-200 and E-200-C are capable of delivering considerably greater audio signal voltage than is required for purposes of internal modulation of the R.F. signal. Accordingly, oversetting the "Modulation

Control" quite understandably injects too great an audio signal into the R.F. amplifier-buffer section. This high audio output, however, is extremely desirable when employed for direct audio tests as described on page (5).

When the audio test signal is to be employed for EXTERNAL usage, the "Audio Signal" switch is no longer set to "MOD. R.F.", but instead to "400 CYCLE AUDIO" position. Then the "Modulation Control" may be set to whatever level is required for the apparatus under test, bearing in mind the information contained in the note on page (6).

On Series E-200-C, percentage modulation settings are direct reading on the OUTSIDE set of numerals.

The INNER ring of numbers, 0-10, represent a purely arbitrary set of figures for reference use when employing the same control for audio signal test purposes or for EXTERNAL modulation percentage control. In such cases the "AUDIO SIGNAL" switch would NOT be in the "Modulated R.F." position.

* * *

MODULATION SETTINGS FOR MODELS PREVIOUS
TO E-200-C BEARING SERIAL NUMBERS
BELOW No. 17801

% MODULATION	CONTROL SETTING
10%	3.4
20%	4.2
30%	4.8
40%	5.2
50%	5.4
60%	5.6
70%	5.8
80%	6.0

NOTE: BAND SWITCH S11 SHOWN IN BAND "A" POSITION, EACH BAND POSITION ADVANCES ROTOR 45°

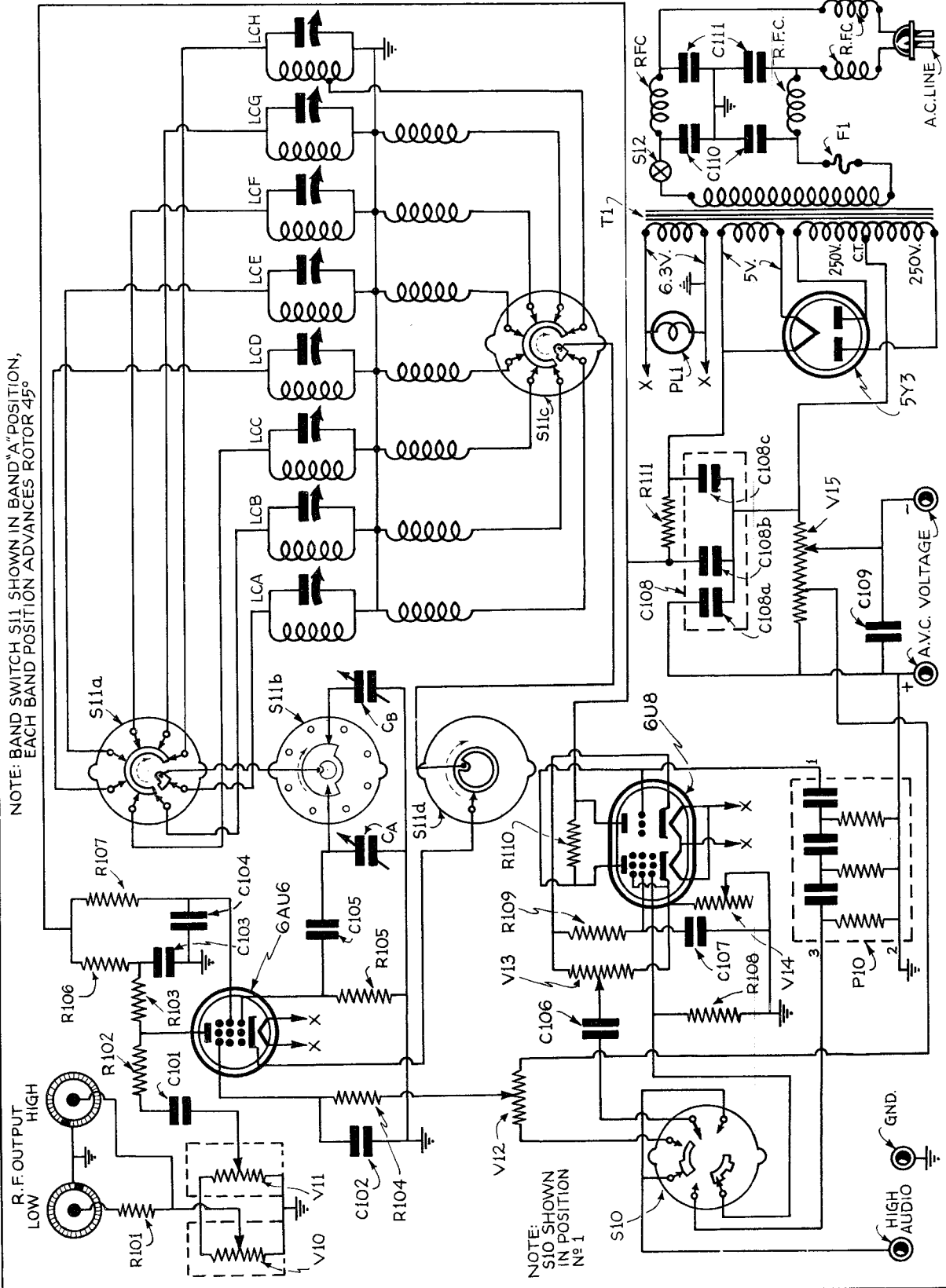

NOTE: S10 SHOWN IN POSITION N° 1

PART No	SPECIFICATION
R111	3000 Ω
R110	47K Ω
R109	56K Ω
R108	470K Ω
R107	39K Ω
R106	15K Ω
R105	47K Ω
R104	15K Ω
R103	1000 Ω
R102	1000 Ω
R101	4000 Ω
C111	.00002 MFD.
C110	.01-MFD.
C109	.01-MFD.
C108	ELECTROLYTIC FILTER BLOCK C108a - 25 MFD, 75 W.V. C108b - 10 MFD, 450 W.V. C108c - 10 MFD, 450 W.V.
C107	.02-MFD.
C106	.01-MFD.
C105	.00005 MFD.
C104	.01-MFD.
C103	.01-MFD.
C102	.0002 MFD.
C101	.002-MFD.
CA-C8	DUAL SECTION TUNING CONDENSER CA-75MMFD. CB-300MMFD.
T1	POWER TRANSFORMER CA-75MMFD. CB-300MMFD.
S12	OFF-ON SW. GANGED WITH V15
S11	BAND SELECTOR SWITCH
S10	AUDIO SIGNAL SWITCH
R.F.C.	R.F. LINE CHOKES
PL1	6.3V-PILOT LAMP
P10	PHASE SHIFT NETWORK
F1	LAMP FUSE
V15	3000 Ω A.V.C. CONTROL
V14	1000 Ω CALIBRATED
V13	40K Ω MODULATION CONTROL
V12	250K Ω SEALED CALIBRATED
V11	200 Ω
V10	200 Ω
LCH	COIL & TRIMMER FOR BAND-H
LCG	COIL & TRIMMER FOR BAND-G
LCF	COIL & TRIMMER FOR BAND-F
LCE	COIL & TRIMMER FOR BAND-E
LCD	COIL & TRIMMER FOR BAND-D
LCC	COIL & TRIMMER FOR BAND-C
LCB	COIL & TRIMMER FOR BAND-B
LCA	COIL & TRIMMER FOR BAND-A

SERIES E-200 C
TITLE: SIGNAL MARKING GENERATOR
STARTING WITH SERIAL N° H58856
DRAWN BY: *Wm. Kadlock Jr.* DATE: 12-7-57
CHECKED BY: *J. Estrems* DATE: 12-9-57